

PCD Tip and Chip-Breaking Grooves

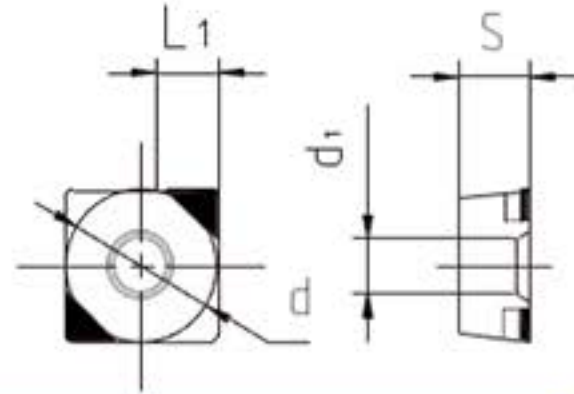

Model	Size				Material		
	d	S	d _i	L _i	GT25	GT10	GT302
SPGT060304SF00-X2	6.35	3.18	2.8	2.8	●	●	●
SPGT060308SF00-X2	6.35	3.18	2.8	2.8	●	●	●
SPGT09T304SF00-X2	9.525	3.97	4.4	3.1	●	●	●
SPGT09T308SF00-X2	9.525	3.97	4.4	3.1	●	●	●

PCD Tip with a Front Angle of 0 Degrees

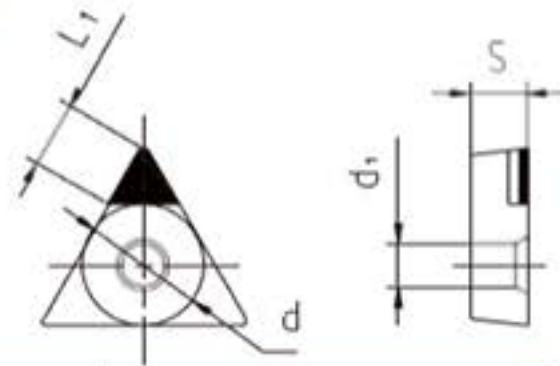

Model	Size				Material		
	d	S	d _i	L _i	GT25	GT10	GT302
TCGW090204SF00-X1	5.56	2.38	2.5	3.4	●	●	●
TCGW090208SF00-X1	5.56	2.38	2.5	3.1	●	●	●
TCGW110204SF00-X1	6.35	2.38	2.8	3.8	●	●	●
TCGW110208SF00-X1	6.35	2.38	2.8	3.5	●	●	●
TCGW16T304SF00-X1	9.525	3.97	4.4	5.4	●	●	●
TCGW16T308SF00-X1	9.525	3.97	4.4	5.1	●	●	●

PCD Tip with a Front Angle of 0 Degrees

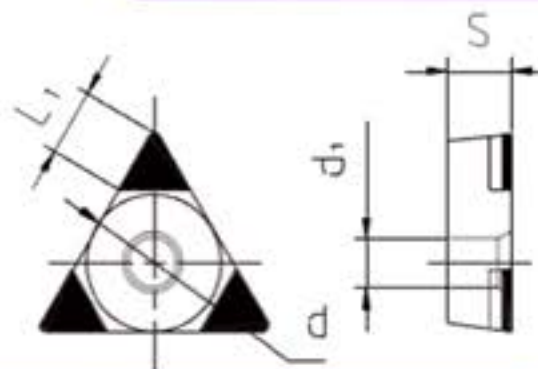

Model	Size				Material		
	d	S	d ₁	L ₁	GT25	GT10	GT302
TCGW090204SF00-X3	5.56	2.38	2.5	3.4	●	●	●
TCGW090208SF00-X3	5.56	2.38	2.5	3.1	●	●	●
TCGW110204SF00-X3	6.35	2.38	2.8	3.8	●	●	●
TCGW110208SF00-X3	6.35	2.38	2.8	3.5	●	●	●
TCGW16T304SF00-X3	9.525	3.97	4.4	5.4	●	●	●
TCGW16T308SF00-X3	9.525	3.97	4.4	5.1	●	●	●

PCD Tip with a Front Angle of 0 Degrees

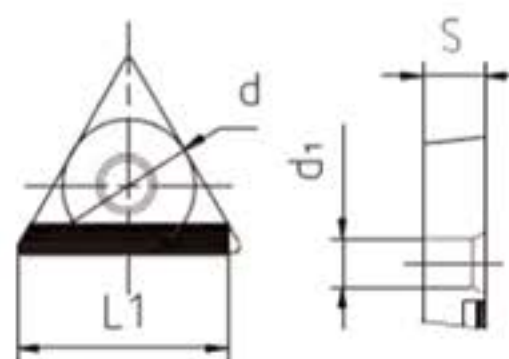
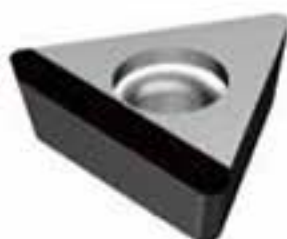

Model	Size				Material		
	d	S	d ₁	L ₁	GT25	GT10	GT302
TCGW090204LF00-R1	5.56	2.38	2.5	8.6	●	●	●
TCGW090208LF00-R1	5.56	2.38	2.5	8.3	●	●	●
TCGW110204LF00-R1	6.35	2.38	2.8	9.8	●	●	●
TCGW110208LF00-R1	6.35	2.38	2.8	9.5	●	●	●
TCGW16T304LF00-R1	9.525	3.97	4.4	15	●	●	●
TCGW16T304LF00-L1	9.525	3.97	4.4	14.7	●	●	●
TCGW090204LF00-L1	5.56	2.38	2.5	8.6	●	●	●
TCGW090208LF00-L1	5.56	2.38	2.5	8.3	●	●	●
TCGW110204LF00-L1	6.35	2.38	2.8	9.8	●	●	●
TCGW110208LF00-L1	6.35	2.38	2.8	9.5	●	●	●
TCGW16T304LF00-L1	9.525	3.97	4.4	15	●	●	●
TCGW16T308LF00-L1	9.525	3.97	4.4	14.7	●	●	●

PCD Tip Front Corner

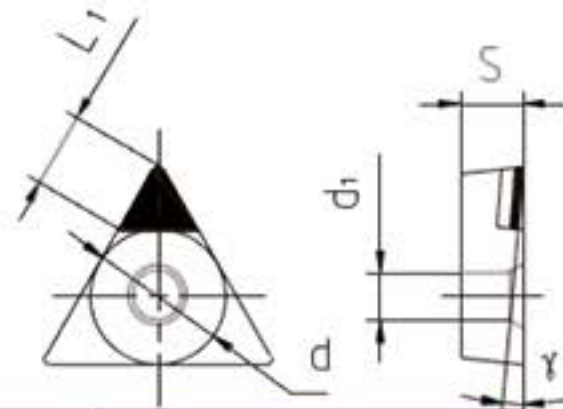

Model	Size				Material		
	d	S	d ₁	L _i	GT25	GT10	GT302
TCGW 090204 SF03-X1	5.56	2.38	2.5	3.4	●	●	●
TCGW 090204 SF04-X1					●	●	●
TCGW 090204 SF05-X1					●	●	●
TCGW 090204 SF07-X1					●	●	●
TCGW 090204 SF10-X1					●	●	●
TCGW 090204 SF15-X1					●	●	●
TCGW 090208 SF03-X1	5.56	2.38	2.5	3.1	●	●	●
TCGW 090208 SF04-X1					●	●	●
TCGW 090208 SF05-X1					●	●	●
TCGW 090208 SF07-X1					●	●	●
TCGW 090208 SF10-X1					●	●	●
TCGW 090208 SF15-X1					●	●	●
TCGW 110204 SF03-X1	6.35	2.38	2.8	3.8	●	●	●
TCGW 110204 SF04-X1					●	●	●
TCGW 110204 SF05-X1					●	●	●
TCGW110204SF07-X1					●	●	●
TCGW110204SF10-X1					●	●	●
TCGW110204SF15-X1					●	●	●
TCGW110208SF03-X1	6.35	2.38	2.8	3.5	●	●	●
TCGW110208SF04-X1					●	●	●
TCGW 110208 SF05-X1					●	●	●
TCGW 110208 SF07-X1					●	●	●
TCGW110208SF10-X1					●	●	●
TCGW110208SF15-X1					●	●	●
TCGW16T304SF03-X1	9.525	3.97	4.4	5.4	●	●	●
TCGW16T304SF04-X1					●	●	●
TCGW16T304SF05-X1					●	●	●
TCGW 16T304 SF07-X1					●	●	●
TCGW16T304SF10-X1					●	●	●
TCGW16T304SF15-X1					●	●	●
TCGW16T308SF03-X1	9.525	3.97	4.4	5.1	●	●	●
TCGW16T308SF04-X1					●	●	●
TCGW16T308SF05-X1					●	●	●
TCGW16T308SF07-X1					●	●	●
TCGW 16T308 SF10-X1					●	●	●
TCGW 16T308 SF15-X1					●	●	●

PCD Tip Front Corner

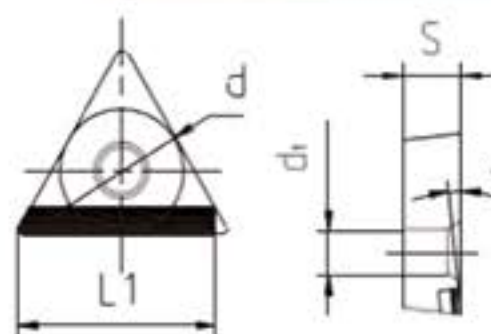
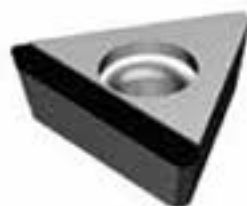

Model	Size				Material		
	d	S	d ₁	L ₁	GT25	GT10	GT302
TCGT090204LF05-R1	5.56	2.38	2.5	8.6	●	●	●
TCGT090204LF07-R1					●	●	●
TCGT090204LF10-R1					●	●	●
TCGT090208LF05-R1	5.56	2.38	2.5	8.3	●	●	●
TCGT090208LF07-R1					●	●	●
TCGT090208LF10-R1					●	●	●
TCGT110204LF05-R1	6.35	2.38	2.8	9.8	●	●	●
TCGT110204LF07-R1					●	●	●
TCGT110204LF10-R1					●	●	●
TCGT110208LF05-R1	6.35	2.38	2.8	9.5	●	●	●
TCGT110208LF07-R1					●	●	●
TCGT110208LF10-R1					●	●	●
TCGT16T304LF05-R1	9.525	3.97	4.4	15	●	●	●
TCGT16T304LF07-R1					●	●	●
TCGT16T304LF10-R1					●	●	●
TCGT16T308LF05-R1	9.525	3.97	4.4	14.7	●	●	●
TCGT16T308LF07-R1					●	●	●
TCGT16T308LF10-R1					●	●	●
TCGT090204LF05-L1	5.56	2.38	2.5	8.6	●	●	●
TCGT090204LF07-L1					●	●	●
TCGT090204LF10-L1					●	●	●
TCGT090208LF05-L1	5.56	2.38	2.5	8.3	●	●	●
TCGT090208LF07-L1					●	●	●
TCGT090208LF10-L1					●	●	●
TCGT110204LF05-L1	6.35	2.38	2.8	9.8	●	●	●
TCGT110204LF07-L1					●	●	●
TCGT110204LF10-L1					●	●	●
TCGT110208LF05-L1	6.35	2.38	2.8	9.5	●	●	●
TCGT110208LF07-L1					●	●	●
TCGT110208LF10-L1					●	●	●
TCGT16T304LF05-L1	9.525	3.97	4.4	15	●	●	●
TCGT16T304LF07-L1					●	●	●
TCGT16T304LF10-L1					●	●	●
TCGT16T308LF05-L1	9.525	3.97	4.4	14.7	●	●	●
TCGT16T308LF07-L1					●	●	●
TCGT16T308LF10-L1					●	●	●

PCD Tip and Chip-Breaking Grooves

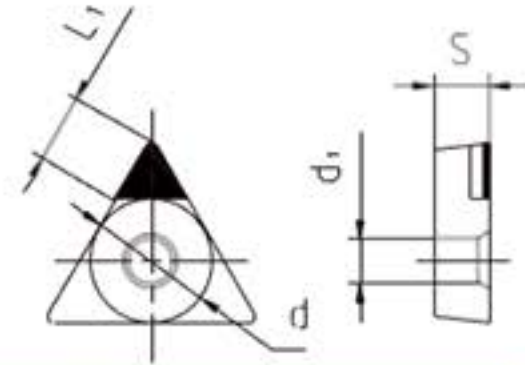

Model	Size				Material		
	d	S	d ₁	L ₁	GT25	GT10	GT302
TCGT1102025F00-X1	6.35	2.38	2.8	3.7	●	●	●
TCGT1102045F00-X1	6.35	2.38	2.8	3.4	●	●	●

PCD Tip with a Front Angle of 0 Degrees

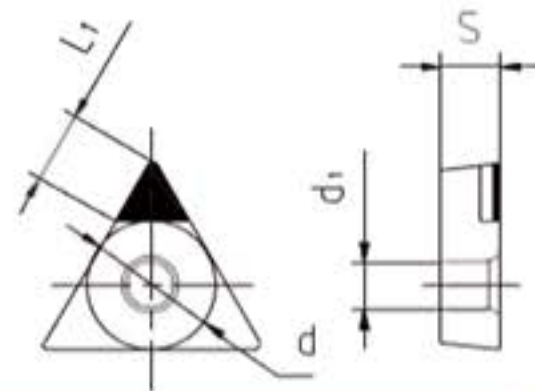

Model	Size				Material		
	d	S	d ₁	L ₁	GT25	GT10	GT302
TPGW0902045F00-X1	5.56	2.38	2.4	3.4	●	●	●
TPGW0902085F00-X1	5.56	2.38	2.4	3.1	●	●	●
TPGW1102045F00-X1	6.35	2.38	2.9	3.8	●	●	●
TPGW1102085F00-X1	6.35	2.38	2.9	3.5	●	●	●
TPGW16T3045F00-X1	9.525	3.97	4.4	5.4	●	●	●
TPGW16T3085F00-X1	9.525	3.97	4.4	5.1	●	●	●

PCD Tip with a Front Angle of 0 Degrees

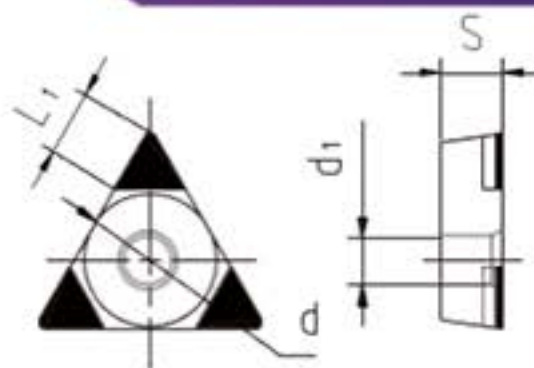
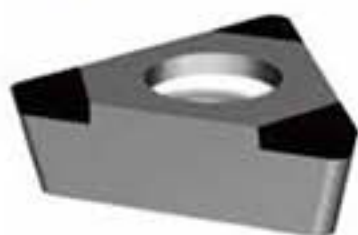

Model	Size				Material		
	d	S	d ₁	L ₁	GT25	GT10	GT302
TPGW090204SF00-X3	5.56	2.38	2.4	3.4	●	●	●
TPGW090208SF00-X3	5.56	2.38	2.4	3.1	●	●	●
TPGW110204SF00-X3	6.35	2.38	2.9	3.8	●	●	●
TPGW110208SF00-X3	6.35	2.38	2.9	3.5	●	●	●
TPGW16T304SF00-X3	9.525	3.97	4.4	5.4	●	●	●
TPGW16T308SF00-X3	9.525	3.97	4.4	5.1	●	●	●

PCD Tip with a Front Angle of 0 Degrees

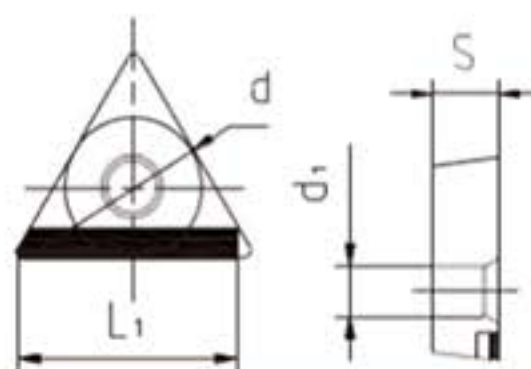

Model	Size				Material		
	d	S	d ₁	L ₁	GT25	GT10	GT302
TPGW090204LF00-R1	5.56	2.38	2.5	8.6	●	●	●
TPGW090208LF00-R1	5.56	2.38	2.5	8.3	●	●	●
TPGW110204LF00-R1	6.35	2.38	2.8	9.8	●	●	●
TPGW110208LF00-R1	6.35	2.38	2.8	9.5	●	●	●
TPGW16T304LF00-R1	9.525	3.97	4.4	15	●	●	●
TPGW16T308LF00-R1	9.525	3.97	4.4	14.7	●	●	●
TPGW090204LF00-L1	5.56	2.38	2.5	8.6	●	●	●
TPGW090208LF00-L1	5.56	2.38	2.5	8.3	●	●	●
TPGW110204LF00-L1	6.35	2.38	2.8	9.8	●	●	●
TPGW110208LF00-L1	6.35	2.38	2.8	9.5	●	●	●
TPGW16T304LF00-L1	9.525	3.97	4.4	15	●	●	●
TPGW16T308LF00-L1	9.525	3.97	4.4	14.7	●	●	●

PCD Tip Front Corner

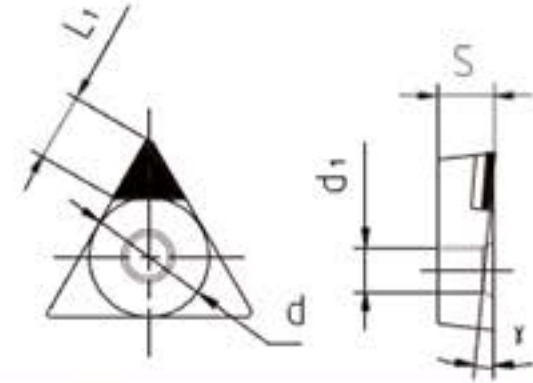

Model	Size				Material		
	d	S	d ₁	L ₁	GT25	GT10	GT302
TPGW090204SF03-X1	5.56	2.38	2.4	3.4	●	●	●
TPGW090204SF04-X1					●	●	●
TPGW090204SF05-X1					●	●	●
TPGW090204SF07-X1					●	●	●
TPGW090204SF10-X1					●	●	●
TPGW090204SF15-X1					●	●	●
TPGW090208SF03-X1	5.56	2.38	2.4	3.1	●	●	●
TPGW090208SF04-X1					●	●	●
TPGW090208SF05-X1					●	●	●
TPGW090208SF07-X1					●	●	●
TPGW090208SF10-X1					●	●	●
TPGW090208SF15-X1					●	●	●
TPGW110204SF03-X1	6.35	2.38	2.9	3.8	●	●	●
TPGW110204SF04-X1					●	●	●
TPGW110204SF05-X1					●	●	●
TPGW110204SF07-X1					●	●	●
TPGW110204SF10-X1					●	●	●
TPGW110204SF15-X1					●	●	●
TPGW110208SF03-X1	6.35	2.38	2.9	3.5	●	●	●
TPGW110208SF04-X1					●	●	●
TPGW110208SF05-X1					●	●	●
TPGW110208SF07-X1					●	●	●
TPGW110208SF10-X1					●	●	●
TPGW110208SF15-X1					●	●	●
TPGW16T304SF03-X1	9.525	3.97	4.4	5.4	●	●	●
TPGW16T304SF04-X1					●	●	●
TPGW16T304SF05-X1					●	●	●
TPGW16T304SF07-X1					●	●	●
TPGW16T304SF10-X1					●	●	●
TPGW16T304SF15-X1					●	●	●
TPGW16T308SF03-X1	9.525	3.97	4.4	5.1	●	●	●
TPGW16T308SF04-X1					●	●	●
TPGW16T308SF05-X1					●	●	●
TPGW16T308SF07-X1					●	●	●
TPGW16T308SF10-X1					●	●	●
TPGW16T308SF15-X1					●	●	●

PCD Tip Front Corner

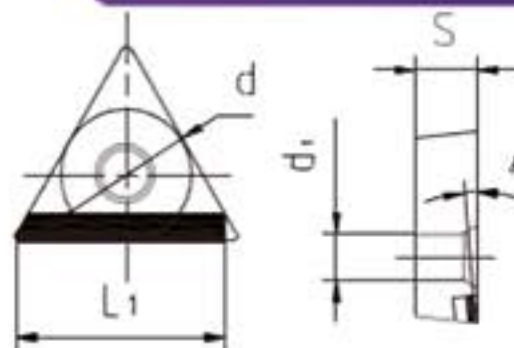

Model	Size				Material		
	d	S	d ₁	L ₁	GT25	GT10	GT302
TPGW090204LF05-R1	5.56	2.38	2.5	8.6	●	●	●
TPGW090204LF07-R1					●	●	●
TPGW090204LF10-R1					●	●	●
TPGW090208LF05-R1	5.56	2.38	2.5	8.3	●	●	●
TPGW090208LF07-R1					●	●	●
TPGW090208LF10-R1					●	●	●
TPGW110204LF05-R1	6.35	2.38	2.8	9.8	●	●	●
TPGW110204LF07-R1					●	●	●
TPGW110204LF10-R1					●	●	●
TPGW110208LF05-R1	6.35	2.38	2.8	9.5	●	●	●
TPGW110208LF07-R1					●	●	●
TPGW110208LF10-R1					●	●	●
TPGW16T304LF05-R1	9.525	3.97	4.4	15	●	●	●
TPGW16T304LF07-R1					●	●	●
TPGW16T304LF10-R1					●	●	●
TPGW16T308LF05-R1	9.525	3.97	4.4	14.7	●	●	●
TPGW16T308LF07-R1					●	●	●
TPGW16T308LF10-R1					●	●	●
TPGW090204LF05-L1	5.56	2.38	2.5	8.6	●	●	●
TPGW090204LF07-L1					●	●	●
TPGW090204LF10-L1					●	●	●
TPGW090208LF05-L1	5.56	2.38	2.5	8.3	●	●	●
TPGW090208LF07-L1					●	●	●
TPGW090208LF10-L1					●	●	●
TPGW110204LF05-L1	6.35	2.38	2.8	9.8	●	●	●
TPGW110204LF07-L1					●	●	●
TPGW110204LF10-L1					●	●	●
TPGW110208LF05-L1	6.35	2.38	2.8	9.5	●	●	●
TPGW110208LF07-L1					●	●	●
TPGW110208LF10-L1					●	●	●
TPGW16T304LF05-L1	9.525	3.97	4.4	15	●	●	●
TPGW16T304LF07-L1					●	●	●
TPGW16T304LF10-L1					●	●	●
TPGW16T308LF05-L1	9.525	3.97	4.4	14.7	●	●	●
TPGW16T308LF07-L1					●	●	●
TPGW16T308LF10-L1					●	●	●

PCD Tip and Chip-Breaking Grooves

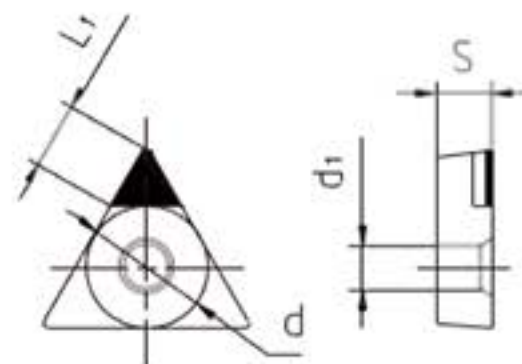

Model	Size				Material		
	d	S	d ₁	L ₁	GT25	GT10	GT302
TPGT1102025F00-X1	6.35	2.38	2.8	3.7	●	●	●
TPGT110204SF00-X1	6.35	2.38	2.8	3.4	●	●	●

PCD Tip Front Corner

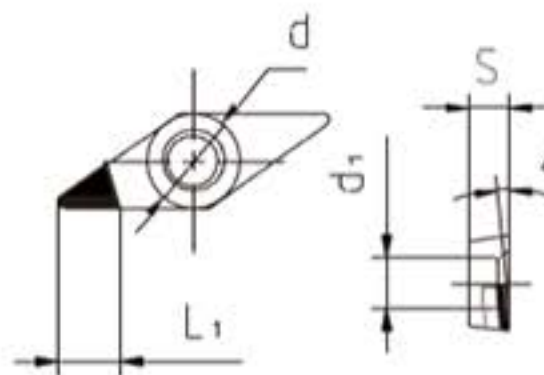
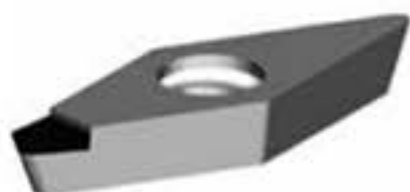

Model	Size				Material		
	d	S	d ₁	L ₁	GT25	GT10	GT302
VBGW110304SF05-X1	6.35	3.18	2.9	4.6	●	●	●
VBGW110304SF07-X1					●	●	●
VBGW110304SF10-X1					●	●	●
VBGW110308SF05-X1	6.35	3.18	2.9	3.9	●	●	●
VBGW110308SF07-X1					●	●	●
VBGW110308SF10-X1					●	●	●
VBGW160404SF05-X1	9.525	4.76	4.4	5.5	●	●	●
VBGW160404SF07-X1					●	●	●
VBGW160404SF10-X1					●	●	●
VBGW160408SF05-X1	9.525	4.76	4.4	5	●	●	●
VBGW160408SF07-X1					●	●	●
VBGW160408SF10-X1					●	●	●